

SMART TRAILERS, INC.

Guaranteed never to jackknife!



[Home](#) | [Products](#) | [Hitch Adapters](#) | [Receiving Your Trailer](#) | [Hitching Trailer to Vehicle](#) | [Order Form](#) | [Warranty](#) | [Return Policy](#) | [Email Us](#) | [About Us](#)

Receiving Your Trailer - Model SL-200

Thank you for your purchase of our NoJAK Trailer. We want your ownership of our trailer to be a pleasant experience.

Because the NoJAK Trailers are unique in design, we take every precaution in making sure it is properly prepared for shipping. It will come packaged upside down and strapped to a wooden pallet. The trailer will weigh about 550lbs. It is therefore recommended that you have 2 or 3 adult males to help uncrate it and turn it over to a rolling position. It will help to follow the suggested steps below. **Be careful!! Avoid getting hurt while handling!!**

Steps:

1. Remove all banding.
2. Remove any boxes of accessories.
3. Mount the tires. Be careful to make sure that all lug nuts are centered in the holes of the rims. Otherwise, the trailer will bounce on the road when traveling. Make sure all lugs are properly torqued.
4. Place 3 pieces of 2x4's about 15 inches long (total of 6 pieces) on top of each other near each end of trailer away from light protector brackets. Then move the rear of the trailer about 2 inches off the pallet to rest on the 2 stacks of 2x4's.
5. Remove cotter pin and castle nut and one white UHMW washer from spindle on front of trailer. Place 2 point hitch on spindle and put UHMW washer on shoulder of spindle. Place castle nut on snugly and insert cotter pin and spread the ends. Use repair links on the short chains near each end of hitch to secure to the hitch. These chains limit the amount of swivel on the hitch.
6. You are now ready to lift the front of the trailer to a vertical position. 2 or 3 adult males should be used for this task. With the trailer being held firmly in a vertical position, move around to the front of trailer to carefully let it down to the pavement. The trailer is now well balanced and one should be able to go to the rear of trailer, and bear down on it, which will raise the front end up and make it easy to push up to the towing vehicle. Please note for the consumers benefit the caster locking pins are secured with the casters in a backing up position. Once the trailer is firmly hitched to the towing vehicle, remove caster locking pins and place in pin keeper on bottom of chassis. **Never, never** tow the trailer with the casters locked in the fixed position.
7. Place the 2 point hitch adapter into the receiver opening of your trailer hitch. Wrap the stabilizing chains around your trailer as below and use Eye-Bolt to tighten the chains:

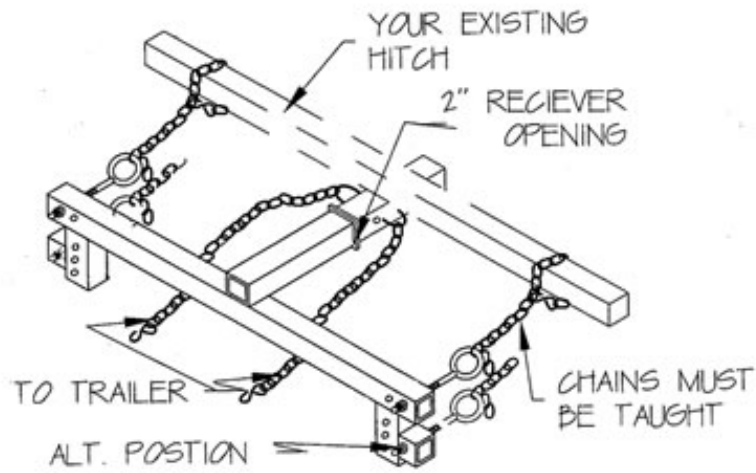

8.

Secure the ball mount brackets to the riser parts on the hitch adapter. The hitch adapter can be inverted when necessary to maintain the correct level of the trailer bed. It is highly recommended that the front of the trailer be a little lower (slightly tilted to the front). This makes it easier for the wheels to swivel.

9.

Firmly tighten ball mount bracket bolts and coupler balls.

10.

Plug in lights, **remove castor locking pins** and enjoy using your trailer.

11.

Always be careful when using your NoJAK trailer. **Do not speed! Do not make sharps turns to the right or left. Observe all traffic regulations.**

© Smart Trailers, Inc

[Home](#) | [Toy Hauler](#) | [Utility Trailer](#) | [Mobility Scooter Lift](#) | [Smart Trailer](#) | [Owners Manual](#) | [Links & Resources](#)